



# Corporate Presentation

May 2026



# FORWARD LOOKING STATEMENTS & DISCLAIMER



This presentation may contain forward-looking statements relating to the Company's operations or to its business environment. Such statements are based on the Company's operations, estimates, forecasts, and projections, but are not guarantees of future performance and involve risks and uncertainties that are difficult to predict or control. A number of factors could cause actual outcomes and results to differ materially from those expressed. These factors include those set forth in the corporate filings.

Although any such forward-looking statements are based upon what management believes to be reasonable assumptions, the Company cannot guarantee that actual results will be consistent with these forward-looking statements. In addition, the Company disclaims any intention or obligation to update or revise any forward-looking statements, for any reason. We also do not commit in any way to guarantee that we will continue reporting on items or issues that arise.

# THE SCANDIUM PLATFORM STRATEGIC FOR THE FUTURE

## CRATER LAKE

- North America's largest primary source of **Scandium**;
- Preliminary Economic Assessment (PEA) July 2022;
- 43-101 Mineral resource latest update April 2025;
- Pre-feasibility study expected summer 2026.

## DEVELOPING AL-SC ALLOYS



Since 2025, **Scandium+** is focusing on three main areas:

- Development of **next-generation aluminum-scandium** alloys and their powders;
- **Pilot projects** and trials with the aerospace, transportation, and energy sectors;
- Validation of materials with **strategic partners**.

# WHY JOIN THE SCANDIUM PLATFORM

- Crater Lake is the **world's largest hard-rock primary source of scandium** currently being developed;
- Scandium is essential for the **reduction of weight of all things that are moving**;
- 90% of current production comes from China and Russia and 100% as a by-product;
- A **long term safe and reliable supply** from multiple sources needed to create Al-Sc alloys markets grow;
- Scandium Canada signed a Contribution agreement for \$6.9M under the Global Partnership Initiative on March 2<sup>nd</sup>, 2026
- Scandium Canada is **fully funded through PFS** with 2026 Federal government support (\$6.9M grant) and successful \$17.25M financing;
- Scandium is necessary to produce super-aluminum alloys: Pre-commercialization tests with potential partners and clients of our two **Al-Sc alloys for advanced manufacturing** underway;
- Ongoing discussion with First Nations communities. – 2024 signed **Pre-development agreement** with Naskapi Nation of Kawawachikamach.



# Why Scandium: a bright future ahead



## Mixed with aluminum, creates alloys

### Lightweight

*Significantly reduce weight of anything that moves;*

### High-Strength

*Greater mechanical resistance without added mass;*

### Corrosion Resistant

*Perform in harsh marine, aerospace & arctic environments;*

### Great Electricity And Heat Conductor

*Efficient in wiring and thermal management applications;*

### Weldable

*Necessary for the manufacturing of primary structures.*

## Main applications for our Al-Sc alloys

### **Aerospace**

Airframes, structural components

### **Automotive & Transports**

Lightweight EV frames, hull components

### **3D Printing & Welding**

Al-Sc powders (L-PBF) & wire arc additive manufacturing (WAAM)

### **Clean Energy & AI**

Solid oxide fuel cells, wind turbines, EV motors

### **Space**

Satellites, Onboard horn antennas

### **Wiring & Heat Exchangers**

Replaces copper in electric motor wiring, industrial heat management systems

*Global Scandium Production: ~35-40 tonnes/year — demand would be far higher if reliable primary supply existed.*

# Scandium Potential Markets

## MARKET DATA

- World production (scandium oxide)  $\approx$ 40 tons/yr.
- Current Global Supply 100% comes as a by-product from mining other minerals;
- Over 90% of current supply comes from China and Russia;
- Multiple new supply SOURCES needed to develop huge latent markets;
- **Automotive** sector:
  - Estimated demand over a 20 years period grows from 0 to **1,350 tons/year**;
- **Aerospace and Defence** sectors:
  - Estimated demand over a 20 years period grows from 2 to **245 tons/year**.

Twenty-year evolution of the potential market size, in tonnes of scandium oxide.

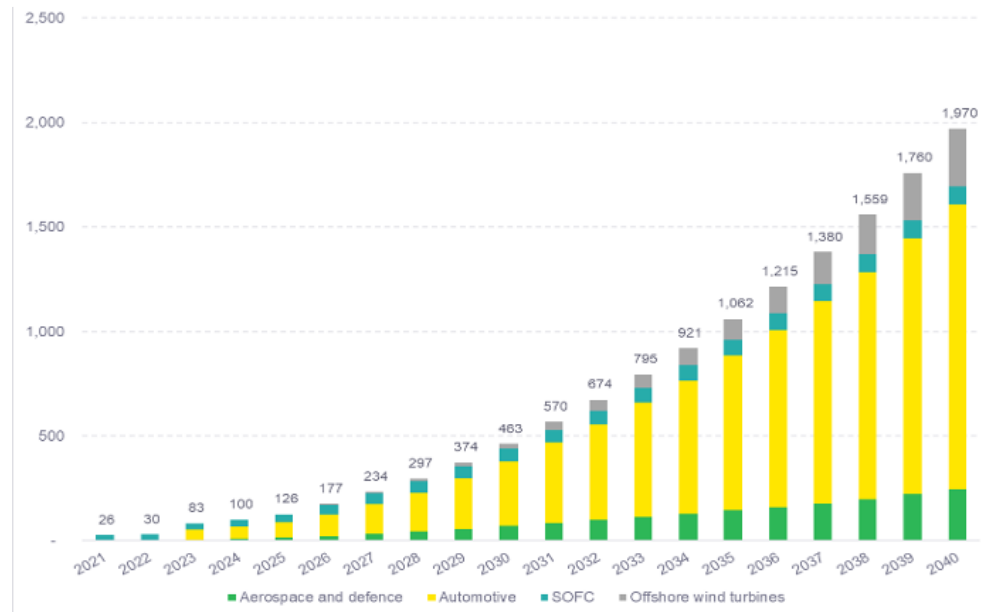

Source: EY Internal Market Study 2022

\*SOFC – Solid Oxide Fuel Cells

# Applications and potential

## OUR MARKET

Scandium Canada is focusing on the **3D printing and welding wire markets.**

Those applications present a strategic opportunity for scandium due to its unique properties that meet the growing needs of high-tech industries.

Demand is rising, technology is advancing, and companies are looking to harness the full potential of this rare element.

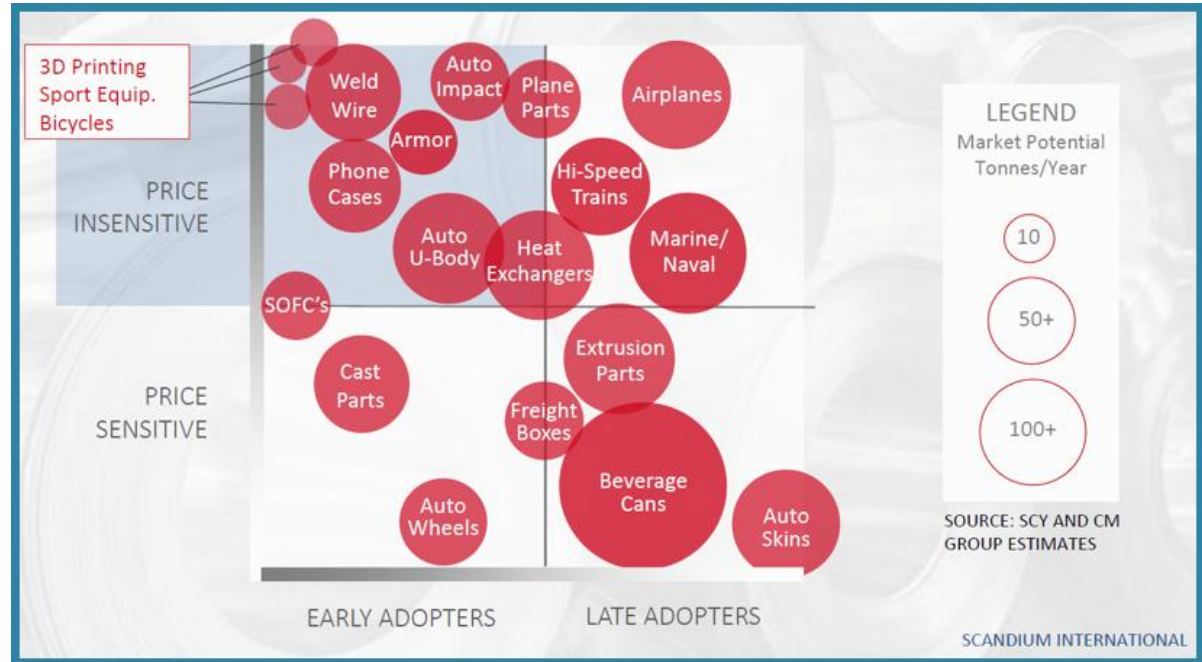

# A division to commercialize Al-Sc Alloys



In 2024, Scandium Canada **filed a provisional patent for two aluminum-scandium alloys and their powders**, developed in partnership with McMaster University in Ontario. A PCT filing followed this first filing in September 2025 to assert worldwide priority.

Scandium Canada **created a specific division** within the Company lead by the current Chief Science officer of the Company, Dr. Luc Duchesne to generate revenues and secure a healthy scandium market in parallel to the development of its Scandium and Rare Earth project in northeastern Quebec.

That division **is fully dedicated to the pre-commercialization** efforts of two proprietary Al-Sc alloys developed by the company to engage with end-users.

# SCANDIUM

A DIVISION OF SCANDIUM CANADA LTD



# 0,4 %

of scandium added to aluminum

= strength multiplied  
up to 8 times  
compared to pure aluminum.

# SCANDIUM

A DIVISION OF SCANDIUM CANADA LTD



Scandium Canada's Al-Sc Alloys Ingots



Al-Sc Powders For L-PBF



3D Printed Complex Components

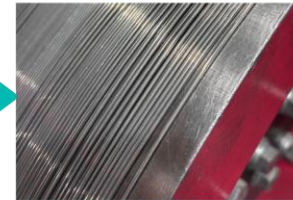

Al-Sc Wires For Welding & WAAM



Large-Scale Structural Parts From WAAM

# Partners & Collaborators



## GOVERNMENT



## INDUSTRY PARTNERS



## RESEARCH CENTRES



## UNIVERSITIES



# CRATER LAKE PROJECT



**“The most exciting scandium hard rock project in the world”**

- Dr. Anthony Williams-Jones, McGill University

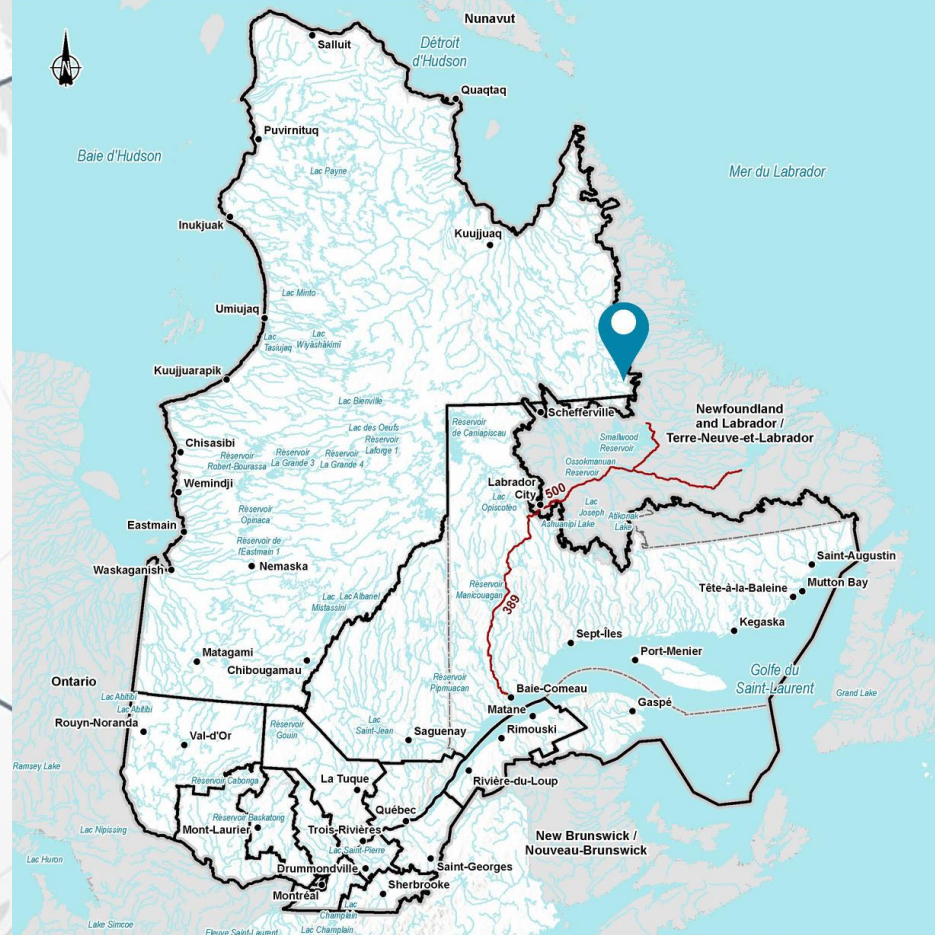

TSXV:  
SCD

# Potential Access Road: Consortium

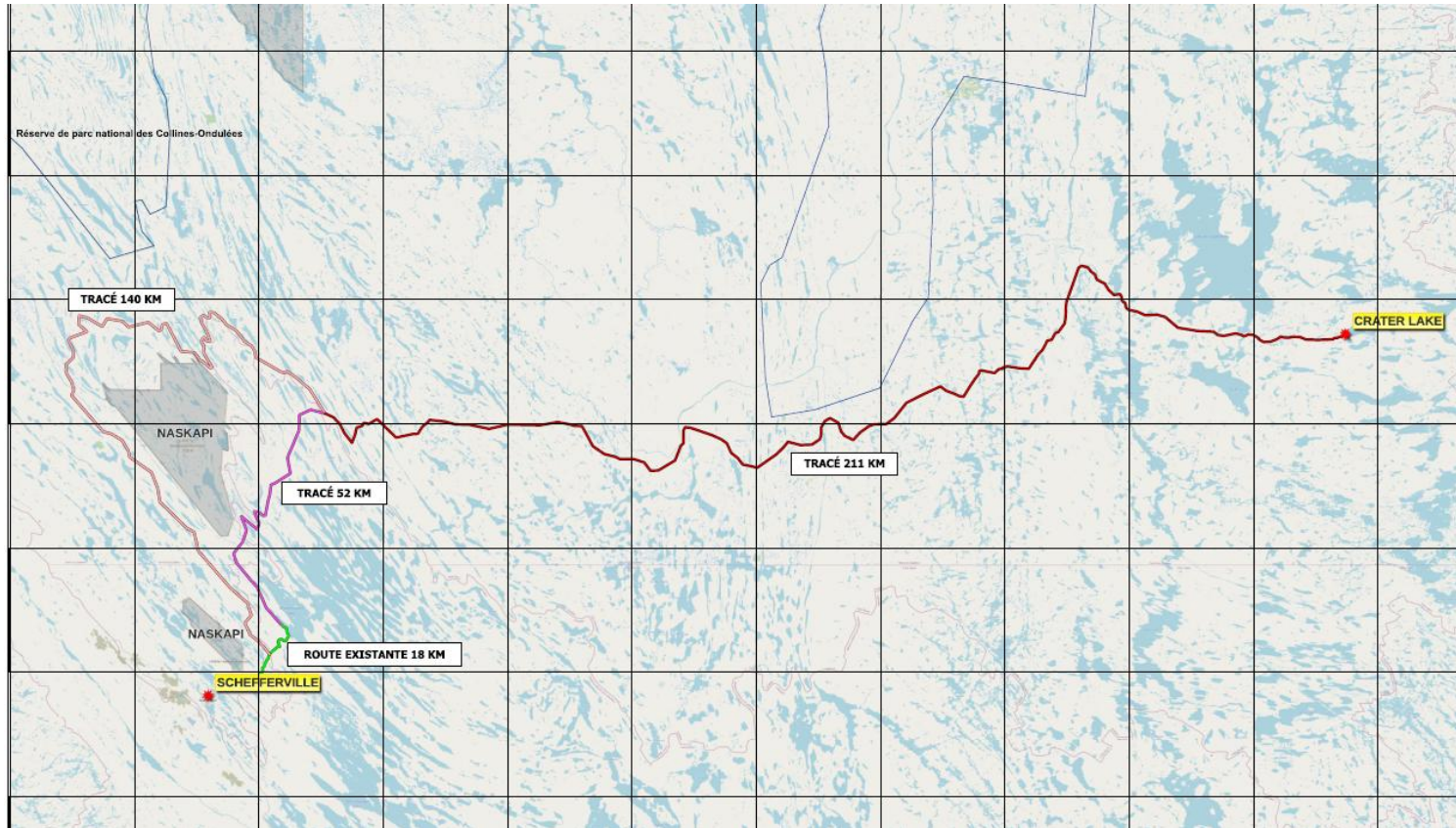

# TG Zone: One Of Many

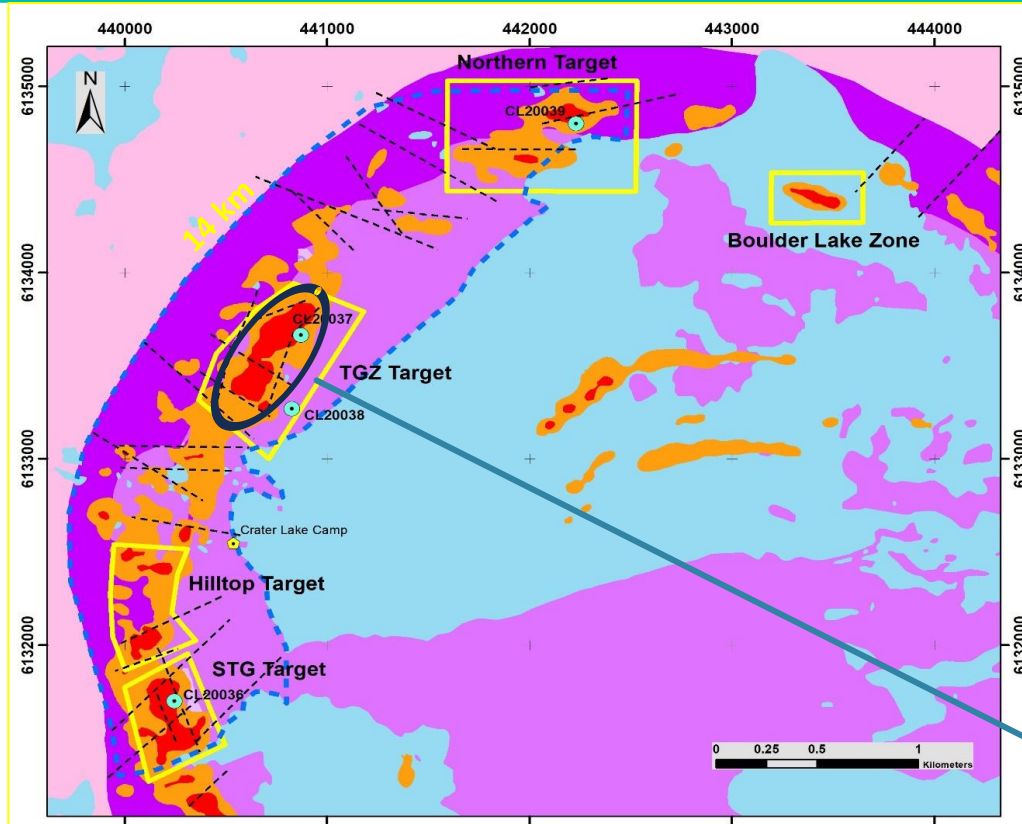

## Legend

-  Camp
-  Imperial DDH 2020

 Target

 Interpreted Fault

## Geophysical Anomalies

 2020 Ground Mag Survey

 Magnetic Anomaly - Very High

 Magnetic Anomaly - High

## Geology

 Coarse Grained Syenite

 Fine to Medium Grained Syenite

**TG Zone Location of 2022 PEA and 2025 MRE**

# TG Zone 43-101 Resource (April 2025)

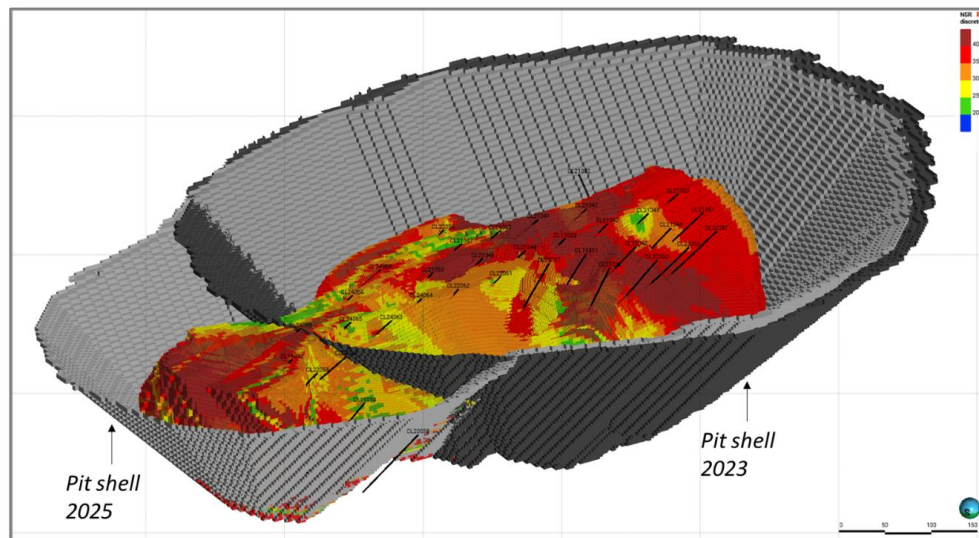

- Zone dimensions: 550m long X 200m in depth: average width 130m. Open in all directions
- Thickens and gets richer at depth
- Cut-off NSR: \$CA 205.54/t;
- Ore value NSR: \$CA 369-379/t
- NSR based on delivery of  $\text{Sc}_2\text{O}_3$  and a bulk Magnet Rare Earth concentrate: additional by-product credits possible.
- The NI-43101 report released on April 2025. The independent persons qualified to estimate mineral resources, as defined by NI 43-101, are Marina Iund, P.Geo., and Simon Boudreau, P.Eng., both of Norda Stelo Inc.

Category	Cut-Off NSR(\$/t)	Tonnage (Mt)	NSR Total (\$/t)	$\text{Sc}_2\text{O}_3$ (g/t)	$\text{Dy}_2\text{O}_3$ (g/t)	$\text{La}_2\text{O}_3$ (g/t)	$\text{Nd}_2\text{O}_3$ (g/t)	$\text{Pr}_2\text{O}_3$ (g/t)	$\text{Tb}_4\text{O}_7$ (g/t)
INDICATED	205.54	16.3	379	277.9	67.3	615.7	604.9	162.3	11.8
INFERRED	205.54	20.9	369	271.9	66.5	609.1	599.1	150.7	11.6

# TG Zone: Position In The Market

Note that the TG Zone of Crater Lake is still open in all directions and is 1 of 5 known Scandium-bearing mineralization on the property.

In addition, Scandium Canada has **two patent pending Al-Sc alloys** – good upside.

[TICKER] - [PROJECT]	Market Cap Feb. 19, 2026	Contained Sc (tonnes)	MC/Tonnes of Sc (rounded)
<b>\$SCD - Crater Lake</b>	\$81 000 000	10 000	\$11,000
<b>\$SCY - Nyngan</b>	\$32 000 000	4 000	\$15,000
<b>\$SRL - Syerston</b>	\$1 240 000 000	21 000	\$66,700

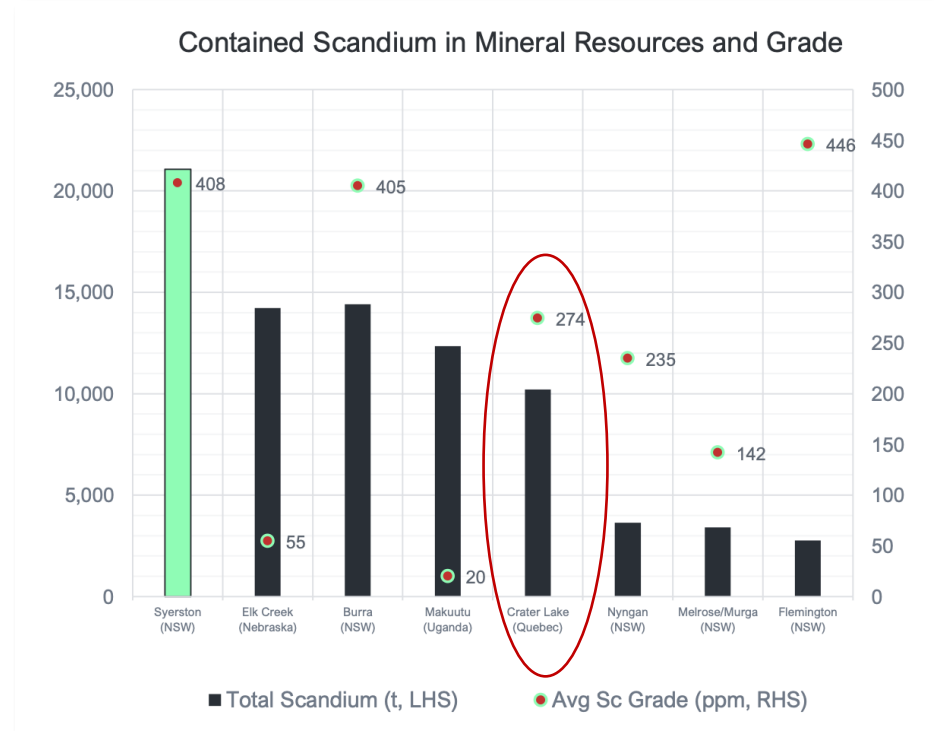

Source: Corporate presentation of Sunrise Energy October 2025

# From Mine to Market

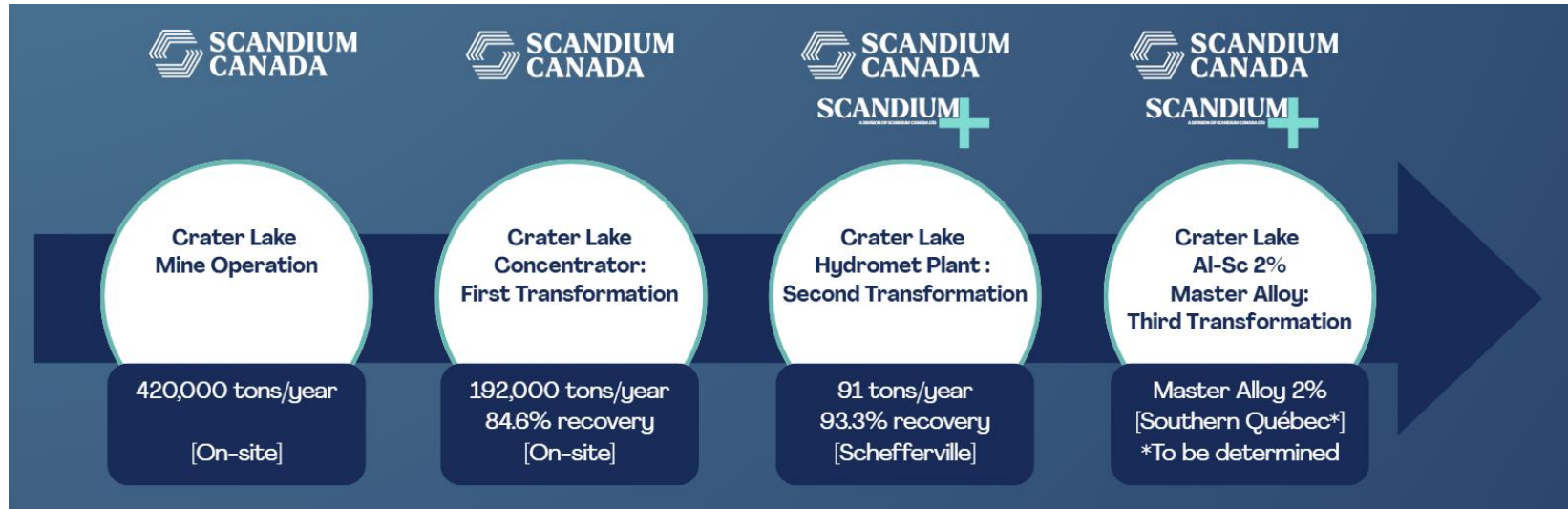

**Scandium Ore**  
Rare Earth Elements



**Scandium Ore**  
Rare Earth Elements



**Scandium Oxide**  
( $\text{Sc}_2\text{O}_3$ )

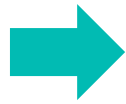

**Aluminium-Scandium**  
2% Master Alloy



# Flow Sheet

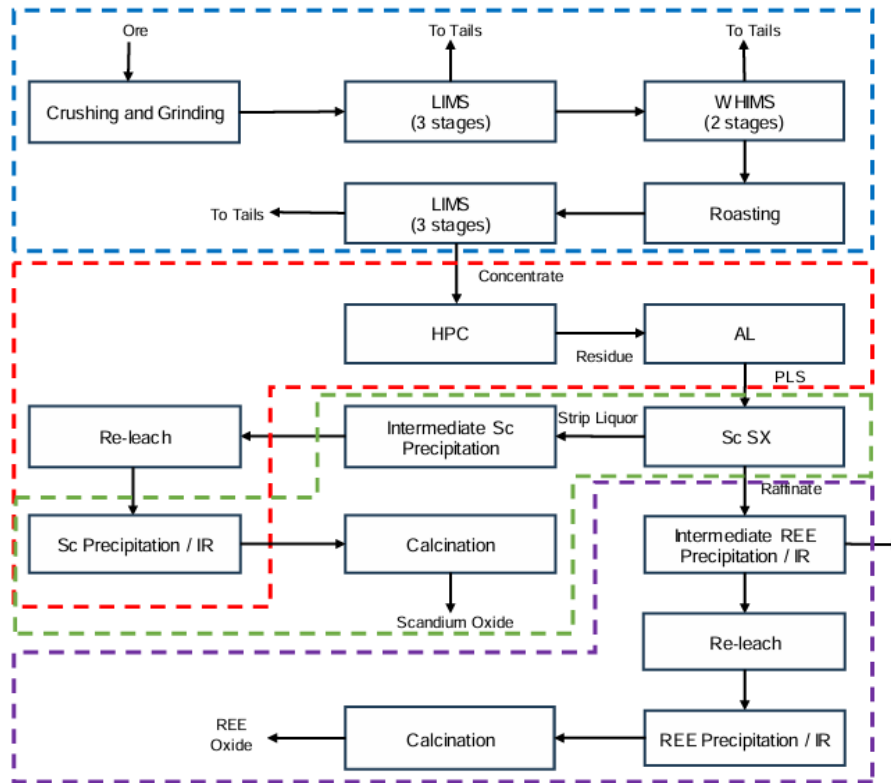

- The Crater Lake ore is first crushed and ground, then subjected to successive magnetic separations: low-intensity LIMS (three stages), followed by high-intensity WHIMS (two stages). A roasting step is applied before the final LIMS to improve liberation. The process yields a Sc/REE-rich concentrate, which will be shipped to Schefferville for hydrometallurgical processing.
- In Schefferville, the concentrate undergoes caustic pressure leaching (HPC, NaOH), which releases scandium from the silicates, followed by HCl leaching (AL) of the residue to produce a pregnant leach solution (PLS). Scandium is then selectively extracted by solvent extraction (Sc SX) and subsequently stripped into a caustic solution. It then goes through an intermediate precipitation, re-leaching, and impurity removal/‘polishing’ steps (IR), before the final precipitation and calcination that produce scandium oxide ( $\text{Sc}_2\text{O}_3$ ). This oxide is used for the production of 2% Al-Sc master alloy.
- The raffinate from the previous step feeds the REE circuit: an intermediate precipitation with impurity removal (IR) is carried out, followed by re-leaching and a final precipitation that yields an REE product (mixed hydroxide/carbonate), potentially followed by calcination depending on buyer specifications. This target product quality was defined based on the requirements of REE processing stakeholders to ensure the value of the co-product.

# The Crater Lake Camp

*4-seasons camp for 20 workers with all the necessary facilities*



# Crater Lake Camp

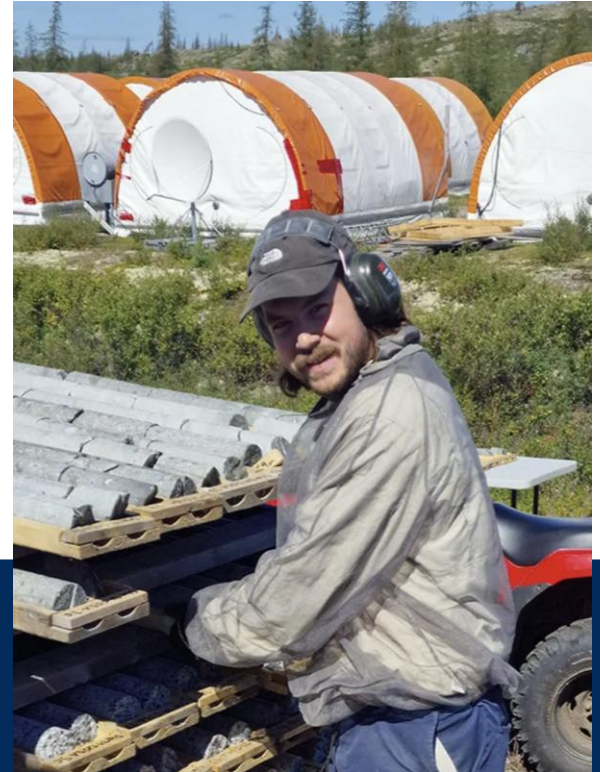

# TG Zone Looking South



# Local Communities

In 2024, Scandium Canada signed a **Pre-Development Agreement (PDA)** with the Naskapi Nation of Kawawachikamach, formalizing a mutual commitment to respect, consultation, participation, and economic benefits.

In 2025, the Taasipitaakin Trust's Board of Trustees decided to **invest in Scandium Canada and acquire 5% of the company.**

Scandium Canada takes pride in its commitments to surrounding communities. Key initiatives undertaken or currently being developed include:

- **Rigorous Environmental Assessments**
- **Partnerships with Local Communities**
- **Natural Resource Management**

Through this partnership, we pledge to work in harmony with the Naskapi Nation to ensure the project aligns with their cultural, social, and environmental values while delivering lasting benefits for present and future generations.



# Capital Structure



## CAPITAL STRUCTURE — MAY 4, 2026

Outstanding shares	466,104,687
Options	21,500,000
Warrants (issued prior to 2026)	91,153,374
Warrants (issued March 2026)	78,409,300
Broker Warrants (issued March 2026)	4,650,558

**FULLY DILUTED** 661,817,919

Options avg. strike price **\$0.09** = **\$1.9M**

Warrants + Broker avg. strike price **\$0.17** = **\$30.0M**

**Total potential cash if exercised** **\$32.0M**



# MEET OUR MANAGEMENT TEAM



**GUY BOURASSA**  
CEO

- Law degree from Laval University
- Over 40 years experience in industrial minerals and strategic metals business.
- Former Founder, President and Director of Nemaska Lithium
- Former President of Dufresnoy Industrial Minerals
- Former director of Nouveau Monde Graphite and Monarques Resources



**PIERRE NEATBY**  
PRESIDENT & COO

- Over 30 years in the base and strategic metals business
- 20 years with Noranda
- 9 years in rare earths with Avalon
- International experience (London, Madagascar) working with consumers in all continents.
- Specific experience in the aluminum business



**STEVE NADEAU**  
CHIEF FINANCIAL OFFICER

- CPA and earned a bachelor's degree in business administration from Moncton University.
- Over 30 years of experience and held senior-level positions across multiple industries.
- Acted as a key negotiator in several major agreements,



**JEAN-FRANÇOIS MAGNAN**  
CHIEF TECHNOLOGY OFFICER

- Former Technical Manager of Nemaska Lithium Inc.
- Held various positions in the industry,
- Promoter and Project Manager at Phostech Lithium Inc.
- Holder of multiple patents in the field of rechargeable lithium batteries.
- Holds a Master's degree in Materials Engineering from Laval University



**DR. LUC DUCHESNE**  
CHIEF SCIENCE OFFICER

- Over 35 years of experience in senior positions across multiple sectors.
- Author and co-author of 85 peer-reviewed scientific articles, literature reviews, and books.
- Holds a Ph.D. from the University of Guelph, an MSc from the University of Toronto and a BSc in Forestry Sciences from Laval University.
- Former senior scientist at Natural Resources Canada
- Recipient of the 5NR Science Award



**CINDY VALENCE**  
SUSTAINABILITY MANAGER

- Former Executive Vice President and Chief Sustainability Officer of Sayona Mining Ltd.
- Expertise in stakeholder engagement for shared value creation.
- Holds an MBA with a specialization in the mineral industry.
- Certified International Trade Professional | PACI |

# BOARD OF DIRECTORS



**JEFF SWINOGA**  
CHAIRMAN

- Senior mining executive with 27+ years across exploration and operations; recognized for team building, strategic transformations, M&A/IPO execution and disciplined capital allocation.
- Senior roles at Barrick Gold, Torex Gold, HudBay Minerals, North American Palladium and Golden Star; Former CEO of Epic Gold and First Mining Gold.
- Capital markets: \$2B+ in project financings and \$400M+ in equity raises.
- Board experience includes Imperial Mining Group, Radisson Mining, Excellon Resources and First Cobalt and Tornbridge Power.
- Trusted governance leader in board oversight, risk management and stakeholder engagement.



**GUY BOURASSA**  
CEO & DIRECTOR

- Law degree from Laval University
- Over 30 years experience in industrial minerals and strategic metals business.
- Former Founder, President and Director of Nemaska Lithium
- Former President of Dufresnoy Industrial Minerals
- Former director of Nouveau Monde Graphite and Monarques Resources



**ROBERT KITCHEN**  
DIRECTOR

- Currently President and CEO of Wasayao Strategic Group
- Brings expertise in community engagement, negotiation, and the development of equity investment strategies for First Nations.
- Former Economic Development Officer for the Cree Nation of Nemaska (2008–2022).
- Has served as director for several private Cree companies, Cree institutions, and the Cree community of Waswanipi.



**CINDY VALENCE**  
SUSTAINABILITY MANAGER &  
DIRECTOR

- Former Executive Vice President and Chief Sustainability Officer of Sayona Mining Ltd.
- Expertise in stakeholder engagement for shared value creation.
- Holds an MBA with a specialization in the mineral industry.
- Certified International Trade Professional | PACI |



**PIERRE NEATBY**  
PRESIDENT – COO  
& DIRECTOR

- Over 30 years in the base and strategic metals business
- 20 years with Noranda
- 9 years in rare earths with Avalon
- International experience (London, Madagascar) working with consumers in all continents.
- Specific experience in the aluminum business



**JEAN LAFLEUR**  
DIRECTOR & AUDIT COMMITTEE

- Geologist with 45+ years of exploration experience in Canada and internationally.
- Former C-suite executive for junior exploration companies in Quebec and Ontario.
- Active consultant since the 2000s via his private geo-consultancy firm.
- Expertise in project evaluation, audits, exploration planning, and investment presentations.
- B.Sc. & M.Sc. in Geology (University of Ottawa); early career with Newmont, Falconbridge, Dome Mines, Placer Dome.

# Strategic Advisory Committee



**MARK KOZDRAS**  
PhD, PEng

Mark S. Kozdras has more than 30 years experience in automotive materials research, development, product design and production. He received a PhD in Mechanical Engineering, specializing in materials science and manufacturing. Through his career he conceived and implemented core industrial process technology in the production of automotive heat exchangers for a major Tier 1 parts supplier, Dana Canada. He has nineteen US product and process patents and considerable technology under trade secret. He spent several years in a manufacturing plant as Product Engineering Manager with design and launch responsibility of heat exchangers for Ford Motor Co. His experience includes several years managing the intellectual property portfolio of Dana Canada. Dr. Kozdras later managed the Automotive Materials R&D program for Natural Resources Canada in its CanmetMATERIALS laboratory. He developed an international profile as Canadian lead of automotive materials research within the International Energy Agency and is currently co-lead of Mission Innovation's, Materials for Energy collaboration platform under the United Nations Framework Convention on Climate Change as well as the co-PI for the German-Canadian Materials Acceleration Centre. He remains active in retirement supporting materials technology and market development.



**NOËL DUBÉ**

Mr. Noël Dubé brings over 20 years of technical experience and success as a leader in the technology sector. He graduated in Engineering Physics. He is a seasoned and active investor in Quebec technology funds. He is a major investor in numerous private investment funds, acting as director, manager and technical advisor to several companies in a specialist capacity, to evaluate technologies, sales and markets and strategic business plan. Previously served as President and Chief Executive Officer of Reflex Photonics from October 2013 until November 2019. Noël Dubé was formerly V.P. Sales & Business Development, member of the board and one of the founders of R/D Tech Inc. R/D Tech was a research and development company which manufactured and commercialized their Non-Destructive testing equipment in more than 50 countries. From 1990 to 2005, he held executive and management positions to support the growth of the company from C\$2M to reach C\$180M along with 600 employees and 12 offices in numerous countries.



**MARC-ANTOINE AUDET**  
Ph.D (geology), P.Geo

Dr. Marc-Antoine Audet, P.Geo, Ph.D Geology, is the President and CEO of Sama Resources Inc, and SRQ Resources Inc., two fast-growing mineral exploration companies involved in base metals exploration in West Africa and in Quebec. During his career, he specialized in Project Management in foreign countries as well as in Mineral Resource and Mineral Reserve estimations and reporting. He was actively involved in exploration projects for Falconbridge/Xstrata Nickel in Canada, Africa, South America, South-Pacific and in Caribbean. In addition to having discovered the Samapleu Ni-Cu-PGE suite of deposits in Côte d'Ivoire and the Lola Graphite deposit in Guinea, his project experience includes the New Caledonia's Koniombo nickel cobalt laterite project, the Falcondo nickel laterite operation in Dominican Republic, the discovery of Serra do Tapas and Vale dos Sonhos nickel cobalt-scandium deposits in Brazil and more recently the discovery of the Gogota nickel cobalt-scandium laterite in Guinea.



# LET'S BRING SCANDIUM TO THE WORLD.



**Guy Bourassa**  
CEO, Scandium Canada



[www.scandium-canada.com](http://www.scandium-canada.com)



[info@scandium-canada.com](mailto:info@scandium-canada.com)



TSX-V: SCD